

TR3200 Series Long-Wave Uncooled Thermal Imager

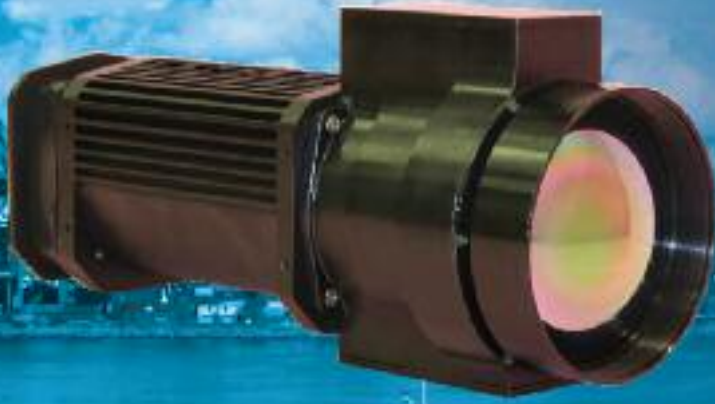

The TR3200 series long-wave uncooled thermal cameras is an effective surveillance solution, delivered in a compact package.

The camera is equipped with a high resolution 320x240 focal plane array (FPA). It can be offered with single, dual FOV and continuous zoom lenses.

The TR3200 series cameras are perfect for security and public safety applications.



Key Features

- Based on advanced VOx technology
- High performance thermal imaging
- Analog video output NTSC or PAL
- Communication control via RS-232
- Easy mounting scheme allows quick deployment
- Dynamic one point NUC
- 2X electronic zoom

Performance Options

- Auto Focus and FOV Control for Multi FOV Camera
- Nitrogen-Purged & Pressurized Enclosure
- Pan-Tilt Drive

Applications

This unique combination of night vision power is Cantronic's solution to the increase need for security and homeland protection at a board range of facilities and infrastructure such as:

- Bridges; Airports; Seaports; Subways
- Military Facilities
- Perimeter Security
- Nuclear Power Plants
- Government Facilities
- Industrial Applications

Available Lenses

Lens	FOV (Hx V)
75mm	5.7°x4.3°
100mm	4.3°x3.2°
45 / 135 mm 2-FOV	12.2°x9.2° WFOV 4.1°x3.1° NFOV
150mm	2.9°x2.2°
210mm	2.1°x1.5°

TR3200 Series Long-Wave Uncooled Thermal Imager

Specifications

Model	TR3200-75	TR3200-100	TR3200-D135	TR3200-150
Lens Focal Length	75mm	100mm	45 / 135mm	150mm
F/#	1.0	1.0	1.1 / 1.6	1.0
Focus Method		Motorized		
Detector Type		320 x 240 VOx Microbolometer		
Spectral Range		8 - 14 μ m		
Pitch		23.5 μ m		
NETD		< 50mK @F/1, 30Hz		
Analog Video Output		NTSC or PAL		
Optics		Auto Focus (Optional)		
System Control		RS232		
Electronic Zoom		2X / 4X		
Frame Rate		30Hz NTSC or 25Hz PAL		
Operating Temperature		-20° to +55°		
Storage Temperature		-40° to +70°		
Dimensions (Lx W x H)		350 x 131 x 164mm (with Sun Shield for TR3200-100)		
Weight		<2KG (without lens)		
Power Supply		12VDC		
Power Consumption		<6W		
Environmental		IP66 Enclosure		

How to Order

TR3200-100 N

Enclosure
 TR3200: Standard
 TR3250: Pressurized

Lens
 75: 75mm Motorized Lens
 100: 100mm Motorized Lens
 150: 150mm Motorized Lens
 210: 210mm Motorized Lens
 D135: 45 /135mm 2-FOV Motorized Lens

Video Output
 N: NTSC
 P: PAL

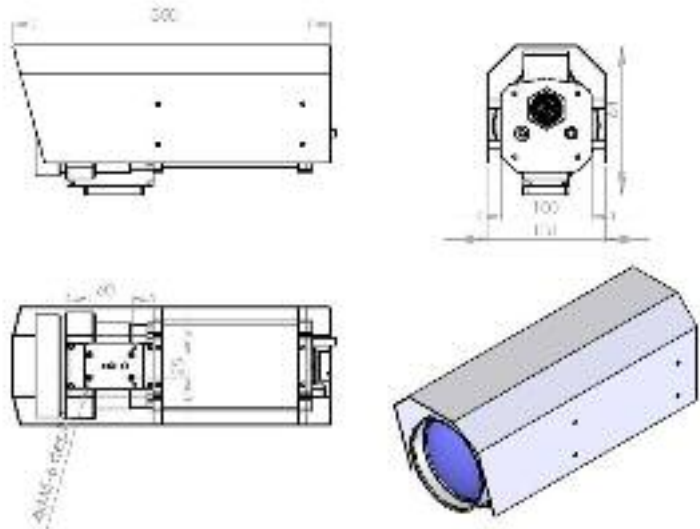

Drawing Shown for Reference only

Cantronic Systems Inc.

63A Clipper Street
 Coquitlam, BC V3K 6X2, Canada
 Tel: 1.604.516.6667
 Tell Free: 1.866.391.6970
 Fax: 1.604.516.6618
 Email: sales@cantronics.com
 Website: www.cantronics.com